

BRL 5220
09-03-2020

Evaluation guideline

For the KOMO® product certificate of

Flexible rubber connectors for non-pressure
sewage systems



Adopted by the CvD LSK d.d. 16-11-2018

Accepted by the KOMO Quality- and Screening
Commission d.d. 25-06-2019

**Trust
Quality
Progress**

Preface Kiwa

This Evaluation guideline has been prepared by the Kiwa Board of Experts LSK (“means Leiding Systemen Kunststof”), in which the parties interested in the field of Flexible rubber connectors for non-pressure sewage systems, are represented. This Board of Experts also guides the performance of certification and adjusts this Evaluation guideline where necessary. Wherever the term ‘Board of Experts’ is used in this Evaluation guideline, the above mentioned Board of Experts is meant.

This BRL will be used by certification bodies, which have a license agreement with the Foundation KOMO, in connection with their established certification procedures. This BRL lays down the requirements for an applicant or holder of a KOMO product certificate and the manner in which the certification body evaluates it. In its established certification procedures, the procedure laid down by the certification body in the implementation of:

- Research for the provision and renewal of a KOMO product certificate based on this BRL;
- Periodic reviews for the maintenance of a KOMO product certificate issued on the basis of this BRL.

The reason for the change is the conversion to the accreditation standard NEN-EN-ISO/IEC 17065.

The following sections have been changed in the BRL:

- In all text NEN-EN 45011 has been replaced by NEN-EN-ISO 17065,
- Paragraph 1.2, before 4.2, text added,
- Paragraph 1.2.1, before 4.1.3,
- Paragraph 4.1, before 4.17, text added,
- Paragraph 4.1.1, before 4.1.4,
- Paragraph 4.2, before 4.3,
- Paragraph 4.3, before 4.4 and 4.7,
- Paragraph 4.4, before 4.5,
- Paragraph 4.4.2, before 4.7, 4.9 and 4.12,
- Paragraph 4.4.4, before 4.12

Kiwa Nederland B.V.

Sir W. Churchillaan 273
P.O. Box 70
2280 AB RIJSWIJK ZH
The Netherlands

Tel +31 (0)88 998 44 00
Fax +31 (0)88 998 44 20
info@kiwa.nl
www.kiwa.nl

© 2020 Kiwa Nederland B.V.

All rights reserved. No part of this publication may be reproduced and/or published by means of printing, photocopying, microfilm or in any other manner whatsoever without the publisher's prior permission in writing. Without prejudice of the approval by the KKTC, all rights rests with Kiwa. The use of this Evaluation guideline for any purpose whatsoever shall only be allowed after the conclusion of a written agreement with Kiwa in which the right of use is arranged

Table of Contents

1	Introduction	4
1.1	General	4
1.2	Product description and fields of application	4
1.3	Relation to European Regulation Construction Products (CPR, EU 305/2011)	5
1.4	Requirements for conformity assessing bodies	5
1.5	Product certificate	5
2	Terminology	6
2.1	General definitions	6
3	Procedure for obtaining a product certificate	7
3.1	Initial investigation	7
3.2	Assesment quality system	7
3.3	Issue of the product certificate	7
4	Product requirements and determination methods	8
4.1	General	8
4.2	Material requirements	8
4.3	Appearance	8
4.4	Dimensional requirement and tolerances	8
4.5	Functional and mechanical requirements	9
4.6	Certification mark	13
5	Quality system requirements	14
5.1	General	14
5.2	Manager of the quality system	14
5.3	Internal quality control/quality plan	14
5.4	Management of laboratory- and measure apparatus	14
5.5	Procedures and work instructions	14
6	Summary of tests and inspections	15
6.1	Test matrix	15
7	Requirements imposed on the certification body	16
7.1	General	16
7.2	Certification staff	16
7.3	Report initial tests	17
7.4	Decision with regard to the issue of the certificate	18
7.5	Nature and frequency of external inspections	18

7.6	Report to the Board of Experts	18
7.7	Interpretation of requirements	18
7.8	Sanction policy	18
8	List of mentioned documents	19
8.1	Norms/ normative documents:	19
Annex A: Example IQC-scheme for product manufacturer		20

1 Introduction

1.1 General

The requirements embodied in this Evaluation guideline (BRL) shall be employed by certification institutes that are accredited by the Dutch Accreditation Council (RvA) and have a licence agreement with the KOMO Foundation when dealing with applications for the issue or maintenance of a product certificate for Flexible rubber connectors for non-pressure sewage applications.

Besides the requirements embodied in this Evaluation guideline, certification institutes impose additional requirements in the sense of requirements with regard to general procedures for certification as laid down in the general certification regulations of the respective certification body.

This Evaluation guideline replaces BRL 5220 dated 11 July 2012. Product certificates issued on the basis of that Evaluation guideline lose their validity at most after one year after binding publication.

Based on the aforementioned previous version of this BRL, new certificates may be issued up to 3 months before the current certificates must be replaced.

The validity period of the certificate is unlimited. The period of validity can be limited (terminated) by:

- an amendment to this Evaluation guideline;
- the certificate holder's failure to meet his obligations.

During the execution of certification activities, the certification bodies have to fulfil the requirements as laid down in the chapter 'Requirements imposed on the certification body'.

1.2 Product description and fields of application

The products are flexible rubber connectors with a diameter up to 1300 mm and intended for use in non-pressure sewage applications. The connectors splings which are indicated in this specification consist of a elastomeric socket with corrosion resistant steel clamp straps and intermediate clamp straps, optionally with an adapter ring. See Figure 1 for the schematic representation of an example.

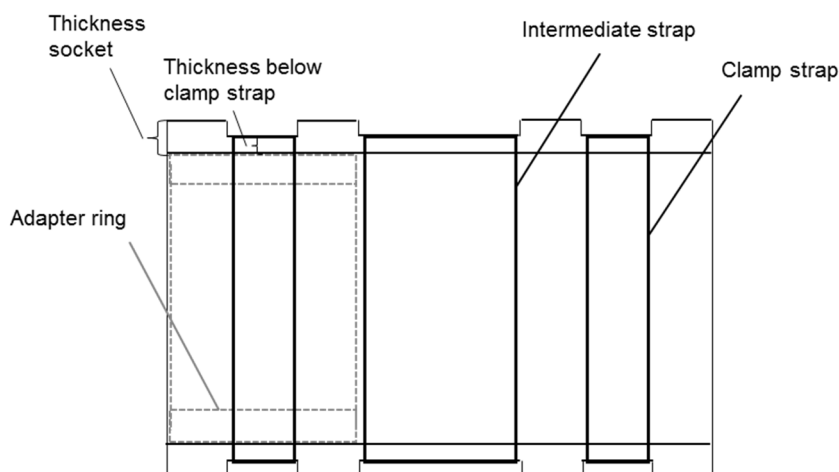

Figure 1 Schematic representation of the components of a flexible rubber connectors

The flexible rubber connectors can be used:

- for repair of damaged piping sections;
- as mechanical connections in non-pressure sewage tubes, or when removing part of the existing sewage and the replacement of this by using a fitting to make new connections easier;
- to connect tubes with different outside diameters;
- combined with adapter rings. This Evaluation guideline is only applicable for the use of a single adapter ring with a flexible rubber connectors.

1.2.1 Use in polluted soil

Some applications where the soil or ground water is contaminated may require extra protection of the connectors. At such environments where the connectors are intended to be used in soil from industrial dump sites or where the soil or ground water contains more than 1000 ppm chloride, the manufacturer should be asked whether the appropriate type of rubber can be applied.

1.3 Relation to European Regulation Construction Products (CPR, EU 305/2011)

The harmonised European standard EN 681-1 is applicable to a number of products within the scope of this Evaluation guideline. These products are those used for sewage systems. The statements in the product certificates issued on the basis of this BRL may not be used to replace the CE marking and/or the corresponding performance statement. The statements in the product certificates issued on the basis of this BRL shall not be used to replace the CE marking and/or the corresponding declaration of performance.

1.4 Requirements for conformity assessing bodies

If the manufacturer submits reports from research bodies or laboratories to show that the requirements of the Evaluation guideline are met, then these reports shall be prepared by a body meeting the prevailing accreditation standard, i.e.:

- EN-ISO/IEC 17020 for inspection bodies;
- EN-ISO/IEC 17021-1 for certification bodies certifying management systems;
- EN-ISO/IEC 17025 for laboratories;
- EN-ISO/IEC 17065 for certification bodies certifying products.

This requirement is being considered to be fulfilled when a certificate of accreditation can be shown, either issued by the Board of Accreditation (RvA) or an institution shall be deemed to meet these criteria when an accreditation certificate for the subject can be consulted, issued by the Accreditation Council (NEO) or another accreditation body accepted as a member of a multilateral agreement on mutual recognition and acceptance of accreditation, drawn up within EA, IAF and ILAC. If no accreditation certificate can be consulted, the certification body will assess whether the accreditation criteria have been met.

The accreditation shall refer to the examination as required in this Evaluation guideline. When no certificate of accreditation can be shown, Kiwa will verify whether the accreditation norm is fulfilled.

1.5 Product certificate

Based on the KOMO-system applicable to this Evaluation guideline, a KOMO® certificate is issued for:

- Product certificate for flexible rubber connectors for non-pressure sewage systems. The claims in this product certificate are based on chapter 4 and 5 (Product requirements and determination methods and Quality system requirements) of this Evaluation guideline.

On the website of 'Stichting KOMO' (www.komo.nl) the template for product certificate applicable for this Evaluation guideline is given. The product certificate to be issued should match with this template.

2 Terminology

For definitions in coherence to certification, one is referred to the website of the KOMO foundation (www.komo.nl) and the regulations of the certifying body.

2.1 General definitions

2.1.1 *IQC-scheme (Internal Quality Control-scheme)*

A description of the quality inspections carried out by the manufacturer as part of this quality system.

2.1.2 *AISI*

Austenitic Stainless and Heat Resistant Steels, a classification system for types of steel.

2.1.3 *Connection Unit*

Part on the clamp strap or intermediate clamp strap with the purpose of connecting the ends and putting tension on the clamp strap.

2.1.4 *Clamp Strap*

Stainless steel strap with connection unit which is located on both outsides of the connector and has the function to connect the connectors watertight on the tube.

2.1.5 *Clamp Strap Unit*

A combination of 2 clamp straps and an intermediate clamp strap.

2.1.6 *Intermediate Clamp Strap*

Stainless steel strap with connection unit which is located at the centre of the connectors and insures the centre lining of the coupled tubes.

2.1.7 *Pull Strap*

The steel part of the clamp strap or intermediate clamp strap without the connection unit.

3 Procedure for obtaining a product certificate

3.1 Initial investigation

In order to obtain a KOMO product certificate, the certification institute will conduct an investigation. The initial investigation comprises of:

- Review of the by the supplier supplied or to be supplied documents, at which time is verified if the with the products combined piping system complies with the performance requirements as stipulated in this Evaluation guideline.
- Determination of the product characteristics as documented in this Evaluation guideline.
- Evaluation of the installation instructions of the supplier.

3.2 Assessment quality system

Furthermore, the initial investigation comprises of:

- Evaluation of the production process;
- Evaluation of the quality system and the IQC-scheme;
- Assessment of the presence and functioning of other required procedures;

A determination has to be made to what extend the quality system is in accordance with the demands as stated in chapter 5 of this evaluation of this guideline.

3.3 Issue of the product certificate

After completion of the initial investigation, the results are presented to the decision-maker. The decision-maker evaluates the results and determines whether the product certificate can be issued or whether additional information and/or investigations are required in order to be able to issue the product certificate.

4 Product requirements and determination methods

4.1 General

In this chapter the performance requirements imposed on flexible rubber connectors for non-pressure sewage systems are included, as well as the determination methods in order to be able to determine whether the requirements are fulfilled.

At setting the requirements the uncertainties of the measurements are taken into account. While measuring and testing a particular value cannot be determined or executed accurately enough, the next lower or higher (of which would be more conservative) value must be used. This implies that drawing conclusions whether requirements are fulfilled these uncertainties do not need to be weighted anymore.

4.2 Material requirements

4.2.1 *Socket and adapter ring*

The elastomeric socket and adapter ring shall be made from compounds based on SBR, NBR or EPDM having a minimum hardness of 60 IRHD.

4.2.2 *Bolts, nuts and straps*

The steel for the bolts, nuts, clamp straps and intermediate clamp straps shall be made from austenitic corrosion resistant steel of a minimal grade of AISI no. 304. In case of the clamp straps rolled heated steel shall be used.

The clamp straps, intermediate clamp straps, pull straps and connection unit shall possess a minimal hardness of 240 Hv.

4.3 Appearance

The tube-ends which are to be connected should not be damaged or distorted by the connectors. All corrosion resistant steel parts shall be free of sharp edges to prevent injuring the installer and damaging the elastomeric socket. Welded parts of the intermediate clamp strap shall have a minimum of three weld points.

4.4 Dimensional requirement and tolerances

4.4.1 *General*

The test equipment for measurements shall be in accordance with ISO 3302-2.

The tolerances of the extruded elastomeric sheets of which the adapter rings and sockets are produced shall be in accordance with class E3 of ISO 3302-2.

4.4.2 *Socket*

The tolerances of the inside diameters of the elastomeric socket shall be in accordance with class M3 of ISO 3302-2.

The diameters of the elastomeric socket shall fulfil the requirements mentioned in table 1. The internal diameter of the elastomeric socket should be checked by measuring the outer circumference and the wall thickness at least at 2 points diametrically opposed to each other on the position where the clamp strap is situated.

The clamp strap is to be removed before the measurement. The internal diameter can be calculated as follows:

Internal diameter = outer circumference/ π – (2 x wall thickness of the socket).

Table 1 Dimensions for socket

<i>Nominal internal diameter in mm</i>	<i>Minimal width of the socket in mm</i>	<i>Minimal thickness below the clamp strap in mm</i>
<i>t/m 199</i>	<i>120</i>	<i>7,0</i>
<i>200 – 299</i>	<i>150</i>	<i>7,5</i>
<i>300 - 1301</i>	<i>185</i>	<i>9,0</i>

4.4.3 Adapter ring

The tolerance of the inside diameter of the adapter (spacer) ring shall be in accordance with class M3 of ISO 3302-2. The internal diameter of the adapter (spacer) should be measured by the same method explained in 4.4.2.

4.4.4 Clamp strap unit

The width and thickness of the clamp strap and intermediate clamp strap should be determined at least 2 points diametrically opposed to each other.

The connector units which are applied in the intermediate clamp strap shall be identical for the aspects of design and specification when compared to the connection units of the clamp straps.

The width of the clamp straps shall not be smaller than 15 mm and the thickness than 0,7 mm. Dimensions for the intermediate clamp strap is shown in table 2.

Table 2 Dimensions for intermediate clamp strap

<i>Nominal internal diameter in mm</i>	<i>Minimal width of the strap in mm</i>	<i>Minimal thickness of the strap in mm</i>
<i>t/m 199</i>	<i>54</i>	<i>0,35</i>
<i>200 – 299</i>	<i>78</i>	<i>0,35</i>
<i>300 - 1301</i>	<i>97</i>	<i>0,75</i>

4.5 Functional and mechanical requirements

4.5.1 Socket and adapter ring

Mechanical requirements for socket and adapter ring shall fulfil the requirements stated in BRL 2013 for rubber type materials with a nominal hardness of 60 IRHD or higher.

4.5.2 Clamp strap unit

The clamp strap unit shall withstand a torque of at least 17 Nm, without any visible damage or distortion of any part, according to the test method explained in 4.5.2.1 – 4.5.2.3.

4.5.2.1 Equipment

A cylindrical mold which does not deform under the applied pressure of the clamp straps. A torque wrench which complies to the accuracy requirements of testing equipment class 2, capable of performing a torque of 17 Nm.

4.5.2.2 Method

The strap to be tested is placed on a mold. The clamp strap units are tightened with the help of the torque wrench until a tightening torque of 17 Nm is achieved.

The straps shall stay in this state for at least 30 minutes and then be untied. Afterwards the clamp strap units shall be visually checked for defects.

4.5.2.3 Test report

The report shall contain at least the following information:

- A) Description of the test sample (supplier, batch, size);
- B) Results of the visual inspection;
- C) Test date.

4.5.3 Resistance welds

The weld points of intermediate clamp straps shall either have a minimal thickness of 2 mm. When sliding off at the spot where the welding points cross each other or be stronger than the original type of metal. The latter must be evident from the fact that during testing no fractures or ruptures may appear in the weld but only in the original material. The welded unit shall resist a tensile force of minimal 6000 N, according to the test method explained in 4.5.3.1 – 4.5.3.4.

4.5.3.1 Equipment

A tensile tester which complies to the accuracy demands of grade 1 testing equipment given in EN ISO 7500-1.

4.5.3.2 Preparation

A piece of non-perforated clamp strap with a length of 100 mm is welded on a piece of intermediate clamp strap of 20 x 100 mm with an overlapping welding piece of 30 mm, as shown in figure 2. The welding equipment, the welding conditions and the welding pattern are to be identical to the regular production of clamp straps.

4.5.3.3 Method

The tests samples are pulled at a cross-head separation rate of 3 mm/min until the (welding) failure, the maximum tensile force is recorded.

4.5.3.4 Test report

The report has to contain at least the following information:

- A) Description of the test sample (supplier, batch, size);
- B) The maximum tensile force at the time of break of the weld or of the original metallic strap;
- C) Test date.

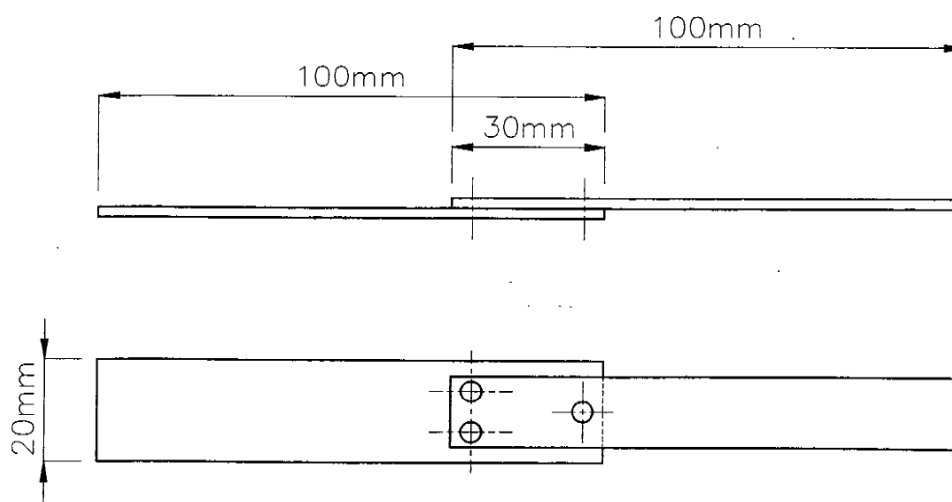

Figure 2 Schematic representation of a tensile test sample for resistance welds

4.5.4 Leak tightness

4.5.4.1 General

The combinations of tube materials in table 3 shall be tested with at least 1 connector unit from each of the three dimensional ranges. The requirements of the test method mentioned in table 3 are summarized in table 4 and are explained in 4.5.4.4.

During the tests under pressure, there shall be no leakage throughout the test.

During the tests under vacuum, the pressure increase in the test unit shall not exceed more than 0,01 MPa and cause any visible leakage.

Table 3 Applied dimensional ranges

Nominal internal diameter in mm	Angle deflection in degrees	Combination of tube materials	Testing method
0 – 399	3	Nodular Cast Iron – PVC-U Concrete – Nodular Cast Iron	B A
400 – 599	1,5	Concrete – Nodular Cast Iron Concrete – Concrete	A A
600 – 1300	1	Concrete – Concrete	C

Table 4 Method of testing

Test method	Fixated tube	Non-fixated tube	Test combination
A	stiff	stiff	pressure and shear (a) pressure and inflection (b)
B	stiff	flexible	pressure and diameter distortion (c) pressure and inflection (b)
C	stiff	stiff	vacuum and shear (d) vacuum and inflection (e)

4.5.4.2 Equipment

The apparatus is to be capable of encompassing 2 tube sections which are connected with a connectors and able to exert shear strength, angular deflection and a constant water pressure or a vacuum in the tube sections.

Both tube ends farthest away from the connectors need to be sealed. The apparatus is to be able to absorb the forces exerted on the tube segments, without shielding the tubes from the test pressure.

Figure 3 presents a schematic display of the apparatus. Both tubes should be centrally aligned lengthwise and the minimum distance between tube ends situated inside the connectors should be 20 mm at the start of the test.

Both other tube ends are enlaced to prevent further shifting in the length during the testing. One tube end has to be supported directly after the connectors and fixated in such a way that during testing no bigger shift than 5 mm can take place. The second tube section has to have a minimal length of 800 mm and has to be supported at the tube end.

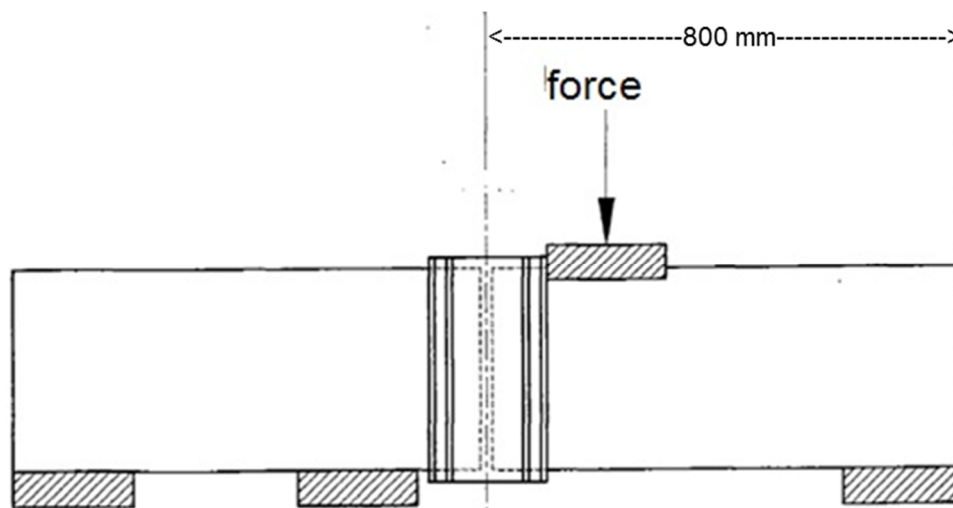

Figure 3 Schematical representation of the apparatus for determination of the leak tightness

4.5.4.3 Preparation

The connectors centrally positioned over the opening between the tubes and all clamp straps are tightened according to the instructions of all the products.

4.5.4.4 Tests

(a) Testing under pressure and shear load

The tubes are placed towards each other, aligned and filled with water with a temperature not exceeding 25 °C. It is important to remove all air from the tubes before applying pressure.

A vertical directed force of 10 N per mm nominal tube diameter is applied on the non supported tube over a distance of 200 mm from the edge of the connectors.

An overpressure of 0,05 MPa is applied during a period of 5 minutes and the system is checked for any leakage.

(b) Testing under pressure and inflection

The pressure of the test unit is released and the vertical force is seized. The tubes are realigned and an angular deflection is set in one tube in respect to the other as described in table 3 with a bending point on the intersection of the centerlines of the tubes within the connectors.

The unit is filled with water as stated in 4.5.4.4.a and the system is checked for any leakage.

(c) Testing under pressure and diameter distortion

The tubes are aligned and a vertical force is applied on the top and bottom side of the non-supported tube section over a distance of 200 mm from the edge of the connectors in order to create a deformation of the outside diameter of 5%. The vertical force must be maintained at this location during this test. The unit is filled with water as stated 4.5.4.4.a. and system is checked for any leakage.

(d) Testing under vacuum and shear load

The tubes are aligned and a vertical directed force of 10 N per mm nominal tube diameter is applied on the non-supported tube over a distance of 200 mm from the edge of the connectors. The tubes are evacuated until the pressure is decreased to an absolute value of 0,075 MPa. The test unit is disconnected from the vacuum pump and the pressure in the test unit is measured after 15 minutes.

In case one of the tubes is made of terra cotta or of concrete and the pressure increase amounts more than 0,01 MPa (thus to an absolute pressure of 0,085 MPa), the inner and outer side of the tube (except for the part which is covered by the connectors) is treated with a kit suitable for this purpose, in order to prevent the inflow of air through the wall and the test is repeated.

(e) Testing under vacuum and inflection

The pressure and the vertical shear force released and the tubes are realigned. An angular deflection is set in one tube in respect to the other as described in table 3 with a bending point on the intersection of the centerlines of the tubes within the connectors. The tubes are evacuated and the test is performed as stated 4.5.4.4.d.

4.5.4.5 *Test rapport*

The report shall contain at least the following information:

- A) Description of the connectors;
- B) Description of the tubes to be used for testing (products, materials, classification and dimensions);
- C) Records of all data in respect to pressure or vacuum, and times;
- D) Results inspection on leakages;
- E) Test date.

4.6 **Certification mark**

The following marks and indications shall be provided on each product and product packaging in a clear, legible and indelible way:



- KOMO® logo (or KOMO® word mark) with certificate number;
- production date or -code;
- name of manufacturer or the deposited trade mark;
- type of rubber applied by means of the letter codes of the nomenclature according to ISO 1629;
- nominal dimension.

5 Quality system requirements

5.1 General

This chapter contains the requirements that have to be met by the supplier's quality management system.

5.2 Manager of the quality system

Within the organisational structure an employee must be appointed who is in charge of managing the quality system.

5.3 Internal quality control/quality plan

The supplier must have an implemented and operational internal quality control scheme in place (IQC-scheme).

In this IQC-scheme the following must be verifiable recorded:

- materials used in the product;
- which aspects are checked by the manufacturer;
- according to which methods these inspections are carried out;
- how often these inspections are carried out;
- how the inspection results are recorded and saved.

This IQC-scheme shall be derived from the example format as shown in annex A. The scheme must be detailed in such a way that it provides CI sufficient confidence that the requirements of this Evaluation guideline are continuously fulfilled.

5.4 Management of laboratory- and measure apparatus

The supplier must determine which laboratory- and measure apparatus are needed based on this BRL in order to demonstrate the product fulfils the requirements:

- When applicable laboratory- and measure apparatus need to be calibrated at specified intervals;
- The supplier needs to validate and register the previous measure results, when at the time of calibration is determined that the laboratory and measure devices are not operating correctly;
- The apparatus in question need to be marked in such a way that can be determined what the calibration status is;
- The supplier is required to register the calibration results.

5.5 Procedures and work instructions

The supplier must be able to submit procedures for:

- the handling of non-conforming products;
- corrective actions in case non-conformities are found;
- the handling of complaints regarding the products and/or services supplied;
- managing work instructions and inspection sheets in use;
- instructions for packaging and closing off products during storage and transport.

5.5.1 Instructions of supplier

Where possible the connectors need to be installed in such a way that the centre lines of the connectors are aligned. The connectors allows a deviation in the alignment of 10 mm. The angular rotation of the connection may not be greater than 5° for tubes till DN 200 mm and 2° for tubes with a larger diameter.

6 Summary of tests and inspections

6.1 Test matrix

The table 4 below contains a summary of the tests and inspections to be performed during certification:

- **Initial tests:** The test to determine if all demands are met as stated in the BRL.
- **Inspection:** the evaluation tests which are held after issuing of the certificate in order to determine if the certified products are meeting the demands continuously; thereby is also noted at what frequency inspections by the certifying institute (CI) are needed.
- **Evaluation of the quality system:** evaluation of the compliance to the IQC schedule and procedures.

Table 5 Summary of the tests and inspections

Description of requirement	Article BRL	Initial evaluation	Surveillance by CI after issue of the certificate ¹⁾	
			Inspection ²⁾	Frequency
<i>Alignment</i>	4.1.1	X	-	-
<i>Material requirements</i>	4.2			
<i>Socket and adapter ring</i>	4.2.1	X	X	1 x year
<i>Bolts, nuts and straps</i>	4.2.2	X	-	-
<i>Appearance</i>	4.3	X	X	1 x year
<i>Dimensional requirements and tolerances</i>	4.4			
<i>Extruded elastomeric sheets</i>	4.4.1	X	-	-
<i>Socket</i>	4.4.2	X	X	1 x year
<i>Adapter ring</i>	4.4.3	X	-	-
<i>Clamp strap unit</i>	4.4.4	X	X	1 x year
<i>Functional and mechanical requirements</i>	4.5			
<i>Socket and adapter ring</i>	4.5.1	X	X	1 x year
<i>Clamp strap unit</i>	4.5.2	X	X	1 x year
<i>Resistance welds</i>	4.5.3	X	-	-
<i>Leak tightness</i>	4.5.4	X	X	1 x year
<i>Marking</i>	4.6	X	X	1 x year
<i>Quality system</i>	5	X	X	2 x year

¹⁾ In case the product or production process changes significantly, the performance requirements must be determined again.

²⁾ By the site assessor or by the supplier in the presence of the site assessor all product properties that can be evaluated within the visiting time (maximum 1 day) are determined. In case this is not possible, an agreement will be made between the certification body and the supplier about how the inspection will take place.

7 Requirements imposed on the certification body

7.1 General

The certification body has to be accredited for the subject of this Evaluation guideline on the basis of EN-ISO/IEC 17065 by the Dutch Accreditation Council (RvA) and have a license of KOMO.

The certification body must have the disposal of a regulation, or an equivalent document, in which the general rules for certification are laid down. In particular these are:

- The general rules for carrying out the initial tests, to be distinguished in:
 - The way suppliers are informed about the handling of the application;
 - Execution of the initial tests;
 - The decision with regard to the initial tests executed.
- The general rules with regard to the execution of inspections and the inspection aspects to be employed;
- The measures to be taken by the certification body in the event of non-conformities;
- The measures to be taken by the certification body in the event of illegitimate use of certificates, certification marks, icons and trademarks;
- The rules for termination of the certificate;
- The possibility of lodging appeal against decisions or measures made by the certification body.

7.2 Certification staff

The staff involved in the certification is to be sub-divided into:

- Certification assessor/ Reviewer: in charge of review of the by the supplier supplied or to be supplied construction drawings and documents, admissions, reviewing of applications and the review of conformity assessments;
- Site assessor: in charge of carrying out external inspections at the supplier's works;
- Decision-maker: in charge of taking decisions in connection with the initial tests performed, continuing the certification in connection with the inspections performed and making decisions on the need of corrective actions.

7.2.1 Competence requirements

Distinguished are:

- Competence requirements for executive certification staff of a CI that fulfil the requirements of EN-ISO/IEC 17065;
- Competence requirements for executive certification staff of a CI that are in addition set up by the Board of Experts for the subject of this Evaluation guideline.

The competencies of the relevant certification personnel must be visibly documented.

Table 6 Competency requirements for the related certification personnel

	Certification assessor/ Reviewer	Site assessor	Decision-maker
General competence			
<i>General education</i>	<ul style="list-style-type: none"> • Higher vocational education 	<ul style="list-style-type: none"> • Intermediate technical vocational education 	<ul style="list-style-type: none"> • Higher vocational education
<i>Knowledge of company processes</i> <i>Competence for professional evaluation</i>	<ul style="list-style-type: none"> • 1 year work experience 	<ul style="list-style-type: none"> • 2 years work experience • Audit training 	<ul style="list-style-type: none"> • 5 years work experience of which 1 year in certification
Technical competence			
<i>Knowledge of the BRL</i>	<ul style="list-style-type: none"> • Detailed knowledge of the specified BRL in question or the BRL's related to each other. 	<ul style="list-style-type: none"> • Witness inspection • Knowledge of the chapters of the BRL which relate to the quality system and the tests. 	<ul style="list-style-type: none"> • n/a
<i>Relevant knowledge of:</i> <ul style="list-style-type: none"> • The technology involved with producing the products to be inspected, the execution of processes and the provisioning of services. • The way products are used, processes are applied and services are rendered; • Any deficiency that can occur during use of the product, any mistake that can be made during the use of a product and any imperfection in the rendering of services. 	<ul style="list-style-type: none"> • Relevant technical higher vocational education work and intellectual level. • At least 1 year of experience in production, testing, inspection and or in the installation trade, including: <ul style="list-style-type: none"> - 2x inspections under supervision • Or internal training course including: <ul style="list-style-type: none"> - 2x inspections under supervision 	<ul style="list-style-type: none"> • Intermediate technical vocational education work and intellectual level. • At least 1 year of experience in production, testing, inspection and or in the installation trade, including: <ul style="list-style-type: none"> - 3x inspections under supervision - 1x independent inspection • Or internal training course including: <ul style="list-style-type: none"> - 3x inspections under supervision - 1x independent inspection 	<ul style="list-style-type: none"> • n/a

7.2.2 Qualification

Certification staff must be demonstrably qualified by evaluation of education and experience of the above-mentioned requirements.

The authority for qualification rests with the management of the certification body.

7.3 Report initial tests

The certification body records the results of the initial tests in a report. The report must fulfil the following requirements:

- Completeness: the report judges about all requirements of the Evaluation guideline;
- Traceability: the findings whereupon the judgements are based must be recorded in a traceable way.

With regard to granting the certificate, the decision-maker must be able to base his decision upon the findings recorded in the report.

7.4 Decision with regard to the issue of the certificate

The decision with regard to the issue of the certificate must be made by a qualified decision-maker, who was not involved at the initial tests. The decision must be traceable recorded.

7.5 Nature and frequency of external inspections

The certification body must enforce inspections at the supplier's site to investigate whether the obligations are met. The Board of Experts advises about the number of inspection visits required. At the time of validation of this Evaluation guideline this frequency has been fixed at four inspection visits per year.

In case the quality system of the supplier is certified on the basis of ISO 9001 quality management system or IATF 16949 is concerned with quality assurance with regard to the production of flexible rubber connectors for free-fall sewers, the frequency is set at 2 inspection visits per year.

If the supplier is a private label owner (identical certificate derived from a product certificate) then the frequency is set at 1 inspection per 2 year.

Inspections shall invariably include:

- The IQC-scheme of the supplier and the results of tests carried out by the supplier;
- The correct marking of the certified products;
- The compliance with the required procedures.

The findings of the inspection visits performed shall be traceably recorded, by the certification body, in a report.

7.6 Report to the Board of Experts

The certification body reports at least once a year about the certification activities performed. In this reporting, the following subjects must be addressed:

- Mutations in number of certificates (new/cancelled);
- Number of inspections carried out in relation to the fixed frequency;
- Results of the inspections;
- Measures imposed in case of non-conformities;
- Complaints received from third parties concerning certified products.

7.7 Interpretation of requirements

The Board of Experts may lay down the interpretation of this Evaluation guideline in a separate interpretation document.

The certification body is obliged to inform whether an interpretation document is available. If this is the case, then the interpretations as laid down in the interpretation document must be employed.

7.8 Sanction policy

The sanction policy and the weighing of shortcomings is available on the service page on the website of the certification body, which has formulated this quality assessment.

8 List of mentioned documents

8.1 Norms/ normative documents:

BRL 2013:2018	Vulcanized rubber products for cold and hot non-drinking water applications
EN-ISO 9001: 2015	Quality management systems – Requirements
IATF 16949: 2016	Quality management system for organizations in the automotive industry
ISO 3302-2: 2008	Rubber - Tolerances for products - Part 2: Geometrical tolerances
EN ISO 7500-1:2018	Metallic materials - Calibration and verification of static uniaxial testing machines - Part 1: Tension/compression testing machines - Calibration and verification of the force-measuring system
NEN-EN 681-1:1996	Elastomeric seals - Materials requirements for pipe joint seals used in water and drainage applications - Part 1: Vulcanized rubber
NEN-ISO 1629:2013	Rubber and lattices - Nomenclature

Annex A: Example IQC-scheme for product manufacturer

<p style="text-align: center;"><u>IQC-schedule</u> <u>INTERNAL QUALITY PLAN</u></p>	<p>Manufacturer / supplier : Production location address :</p>	<p>Number of appendices:</p>
<p><u>Field(s) of application</u></p> <p><u>According Evaluation guideline (s)</u></p>		
<p><u>Number of production shifts:</u></p>	<p><u>Quality manual, procedures and working instructions</u> Is the Quality Management System (QMS) certified according to ISO 9001¹⁾? If yes, by which certification body: If yes, is the certification body accredited for the particular scope of certification?</p>	
<p><u>Quality Control</u> Total number of employees in QC department : Number of QC-operators per shift : If no QC-inspections are carried out during night shifts, state the QC procedure(s)/instruction(s) to be followed: , documented in:</p>	<p>In case the QMS is not certified according to ISO 9001:</p> <ul style="list-style-type: none"> • Working instructions, test instructions and procedures are documented as follows: • The following procedure for dealing with <u>complaints</u> applies: • The following procedure for <u>nonconformity review</u> applies: 	
<p><u>Inspection and test records</u> All records shall be maintained for a minimum of years.</p>		
<p><u>Specific agreements/comments/explanations</u></p>	<p>Signature of the manufacturer/supplier:</p> <p>Date :</p>	

¹⁾ In case the QMS is ISO 9001 certified and covers the scope of the product certificate(s), reference to the applicable procedure(s) on the next pages is sufficient and the tables A till F do in principle not have to be further filled-out except for the frequency of tests/inspections (to be approved by **CI** in tables B, C and D.

A. Calibration of measuring and test equipment Applicable procedure(s) nr(s):				
Equipment to be calibrated	Calibration aspect	Calibration method	Calibration frequency	Calibration file (name and location)

B. Raw material and additives Applicable procedure(s) nr(s):				
B.1 Receipt For each delivery of raw material or additives data with respect to dates, producers, types and quantities are recorded as follows:				
B.2 Entry control				
Type of raw material	Inspection aspect	Inspection method	Inspection frequency	Registration file (name and location)

C. Batch release tests per machine (including in-process and finished product testing) Applicable procedure(s) nr(s): Production process(es):				
Type of product	Type of test	Test method	Test frequency	Registration file (name and location)

Specific agreements/comments/explanations:

D. Process verification tests Applicable procedure(s) nr(s):				
Type of product	Type of test	Test method	Test frequency	Registration file (name and location)

E. Control of nonconforming and/or rejected products Applicable procedure(s) nr(s):				
E.1 Method of registration				
E.2 Method of identification				
E.3 Method of nonconformity review and disposition				

F. Inspection with regard to packaging, storage and transportation of the finished product Applicable procedure(s) nr(s):				
Inspection aspects	Inspection method	Inspection frequency	Registration file (name and location)	
F.1 Packaging/storage/ transportation etc				

Specific agreements/comments/explanations:

Raw materials list (not required to fill-out this appendix in case reference can be made to the CI ATA part of the certification agreement)		Appendix I Date:	
<p>I.1 The product is built-up of the following raw materials:</p> <p>a) In case of products made from ready-made raw materials: listing of name and/or unique code of the raw material(s);</p> <p>b) In case of products made from own compounded raw materials: reference to raw material/compound sheets which are (only) available at the production location and which have to be authenticated by CI (e.g. by the CI inspector);</p> <p>c) In case of composed products (e.g. plastics fitting body, with separate nut, clamp ring and rubber sealing ring): of each part a specification according to a) or b) (whatever applicable).</p> <p>-</p> <p>-</p> <p>-</p> <p>-</p> <p>-</p> <p>-</p> <p>-</p> <p>-</p>			

List of technical drawings			Appendix II Date:.....
Drawing title and number	Drawing date	Drawing title and number	Drawing date