

AR 7
February 2019

Approval requirement 7

Bendable gas meter connection tubes



Trust
Quality
Progress

Foreword

This GASTEC QA Approval requirement has been approved by the Board of Experts product certification GASTEC QA, in which relevant parties in the field of gas related products are represented. This Board of Experts supervises the certification activities and where necessary require the GASTEC QA Approval requirement to be revised. All references to Board of Experts in this GASTEC QA Approval requirement pertain to the above mentioned Board of Experts.

This GASTEC QA Approval requirement will be used by Kiwa Nederland BV in conjunction with the GASTEC QA general requirements and the KIWA regulations for certification.

Approved by Board of Experts : February 10, 2019

Accepted by Kiwa Nederland B.V. : February 10, 2019

Kiwa Nederland B.V.

Wilmersdorf 50
Postbus 137
7300 AC Apeldoorn

Tel. 088 998 33 93
Fax 088 998 34 94
info@kiwa.nl
www.kiwa.nl

© 2017 Kiwa N.V.

All rights reserved. No part of this book may be reproduced, stored in a database or retrieval system, or published, in any form or in any way, electronically, mechanically, by print, photoprint, microfilm or any other means without prior written permission from the publisher.

The use of this evaluation guideline by third parties, for any purpose whatsoever, is only allowed after a written agreement is made with Kiwa to this end

Contents

	Foreword	1
	Contents	2
1	Introduction	4
1.1	General	4
1.2	Scope	4
2	Definitions	5
3	Product requirements	6
3.1	Material	6
3.2	Construction	6
3.2.1	Connections	6
3.3	Dimensions	6
3.3.1	Wall thickness	6
3.3.2	Internal diameter	6
3.3.3	Gas meter connection tube length	6
4	Performance requirements and test methods	7
4.1	General	7
4.2	Stress corrosion resistance	7
4.2.1	Test method (magnesium chloride)	7
4.3	Leak tightness	7
4.3.1	Test method	7
4.4	Pressure loss	8
4.4.1	Test method	8
4.5	Strength of fittings	9
4.5.1	Test method	9
4.6	Resistance to internal pressure	9
4.6.1	Test method	9
4.7	Resistance to pull out	9
4.7.1	Test method	9
4.8	Resistance to bending	9
4.8.1	Test method	9
4.9	Resistance to impact	10
4.9.1	Test method	11
4.10	Self-extinguishing test method	11
5	Marking, instructions and packaging	12
5.1	Marking	12
5.2	Instructions	12

5.3	Packaging	12
6	Quality system requirements	13
7	Summary of tests	14
7.1	Test matrix	14
8	List of referenced documents	15
8.1	Standards / normative documents	15

1 Introduction

1.1 General

This GASTEC QA approval requirement in combination with the GASTEC QA general requirements include all relevant requirements, which are adhered by Kiwa as the basis for the issue and maintenance of a GASTEC QA certificate for bendable gas meter connection tubes.

This GASTEC QA Approval requirements replace the GASTEC QA Approval Requirements 7, bendable gas meter connection pipes, dated March 2012.

List of changes:

- The general requirements related to the certification process, requirements to the quality system and requirements to the certification body have been removed. Textual changes have been made. Requirements that were not verifiable have been removed.
- Material requirement have been changed. The materials to be used are no longer specified. The supplier shall demonstrate the suitability of the material.
- The type of connection is no longer specified. The connection shall be in compliance with the relevant GASTEC QA approval requirements or other national or international standard.
- Requirements for stress corrosion resistance for copper alloys have been added
- Test method for determining self-extinguishing has been added. The self-extinguishing properties was already a requirement, but no test method was described.
- Resistance to high temperatures has been removed. The purpose of this test was to exclude certain materials. Now covered by chapter 3.1.
- Resistance to chemical influences has been removed. Now covered by chapter 3.1.
- Requirement for strength of fittings has been changed. This requirement is only applicable for fittings with flat sealings.
- Chapter 5: Instructions shall be provided in the Dutch language.
- Chapter 6: Quality system requirements have been added.
- Chapter 7: Test matrix has been updated.

1.2 Scope

These approval requirements specify the requirements for gas meter connection tubes with a nominal inside diameter of 20, 25, 40 or 50 mm, suitable for 2nd and 3rd family gas according to EN 437 with a maximum pressure of 200 mbar.

2 Definitions

In this approval requirement, the following terms and definitions are applicable:

Gas meter connection tube: a bendable corrugated metal tube with metal couplers for connecting from the above ground connection pipe or gas pressure regulator to the gas meter or from the gas meter to the installation or gas failure protection device.

Corrugated metal tube: metal tube, spiral shaped or parallel corrugated construction. Optional provided with a protection layer.

Leak tight: A product is considered as being leak tight when following criteria are met:
If the test fluid is a liquid, visually detectable leakage is not permitted
If the test fluid is a gas:
When submerged in water no bubbles are permitted.
When using a leak detection fluid, no continuous formation of bubbles is permitted.

3 Product requirements

3.1 Material

All materials shall be suitable for its application (pressure, ambient temperature range, corrosion resistance, long term behaviour). The suitability can be proven by reference to relevant product standards (for example ISO 10380) for similar products, in which the material is specified.

The material shall be specified according to the relevant material standardisation.

If synthetic materials are used for the protective layer, they shall be self-extinguishing and shall not affect the metals in any way.

Rubber seals shall conform to EN 549 with minimum temperature classification A2 or EN 682, type GAL or GBL.

3.2 Construction

The gas meter connection tube shall not have any dents, any type of cracks or other deficiencies.

3.2.1 Connections

The gas meter connection tube shall be provided with a fitting on both sides of the tube. The fitting shall be specified and shall be in compliance with the relevant GASTEC QA approval requirement or national or international standard.

The connecting pieces between fitting and corrugated tube shall be connected by welding or using hard solder.

3.3 Dimensions

3.3.1 Wall thickness

The wall thickness of the corrugated tube shall at no point be less than 0,25 mm excluding the thickness of the protective layer.

3.3.2 Internal diameter

The nominal internal diameter of the gas meter connection tube shall be chosen from the range:

- 20 mm ($\frac{3}{4}$ "
- 25 mm (1")
- 40 mm (1 $\frac{1}{2}$ "
- 50 mm (2")

3.3.3 Gas meter connection tube length

The length of the gas meter connection tube shall be according to the table below.

nominal internal diameter (mm/inch)	Minimum length corrugated tube (mm)	Minimum length (mm)	Maximum length (mm)
		Including fitting	
20 mm ($\frac{3}{4}$ "	100	230	550
25 mm (1")	125	280	550
40 mm (1 $\frac{1}{2}$ "	200	320	550
50 mm (2")	250	370	550

Table 1

4 Performance requirements and test methods

4.1 General

Each tube diameter shall be tested without protective sleeve.

Unless specified otherwise the tests shall be performed at an ambient temperature of $23 \pm 5^{\circ}\text{C}$.

Unless specified otherwise each test is performed on a separate sample. Per test one sample shall be tested.

Leak tightness test are performed using air.

4.2 Stress corrosion resistance

All parts shall resistant to stress corrosion.

For stainless steel parts the magnesium chloride test shall be performed according to 4.2.1. After exposure there shall be no visual signs of cracks using a magnification of 5 times.

Part made from copper alloys shall be teste by an ammonium chloride test according to ISO 6957 (pH 9,5). No visual signs of cracks shall be observed with a magnification of 10 to 15 times.

4.2.1 Test method (*magnesium chloride*)

The test is performed on tubes without protective layer.

The gas meter connection tube is degreased with acetone and bend once over an angle of 90° with a radius according to table 4 (See paragraph 4.8.1). The tube is filled with glass balls. The ends of the tube shall be sealed to prevent the glass balls form falling out.

Dissolve 1000 g $\text{MgCl}_2 \cdot 6\text{H}_2\text{O}$ per 500 ml distilled water, or proportional amounts thereof. There shall be sufficient fluid to completely immerse the tube.

Heat a vessel to $130 \pm 2^{\circ}\text{C}$ and place the tube in the fluid for 108 hours let the fluid cool down to $70^{\circ}\text{C} \pm 2^{\circ}\text{C}$ and leave the tube for 60 hours.

It can be necessary that a small amount of magnesium chloride or distilled water must be added in order to reach the 130°C .

Make sure that the heating takes place uniformly (avoid bumps and jolts).

The assessment of the connection pipe takes place visually with the aid of a 5x magnifying glass.

4.3 Leak tightness

The gas meter connection tube shall be leak tight at 1 bar pressure during 300 seconds.

4.3.1 Test method

The gas meter connection tube is sealed at one side the other side is used to supply an air pressure of 1 bar. For a period of 300 seconds there shall be no visual signs of leakage.

4.4 Pressure loss

The pressure loss specified by the supplier shall be verified using the air flow as specified below in table 2 at 25 mbar inlet pressure. The measured pressure loss shall not exceed the pressure loss specified by the supplier.

Nominal internal diameter (mm/inch)	Air flow (m ³ /h) ¹⁾
20 (¾")	4
25 (1")	8
40 (1½")	16
50 (2")	30

¹⁾ Standard m³/h

Table 2

4.4.1 Test method

For determining the pressure loss, the test setup shall be according to figure 1. By using the inlet pressure regulator and the control valve the values according to table 3 are set. The inlet pressure at this setting shall be 25 mbar.

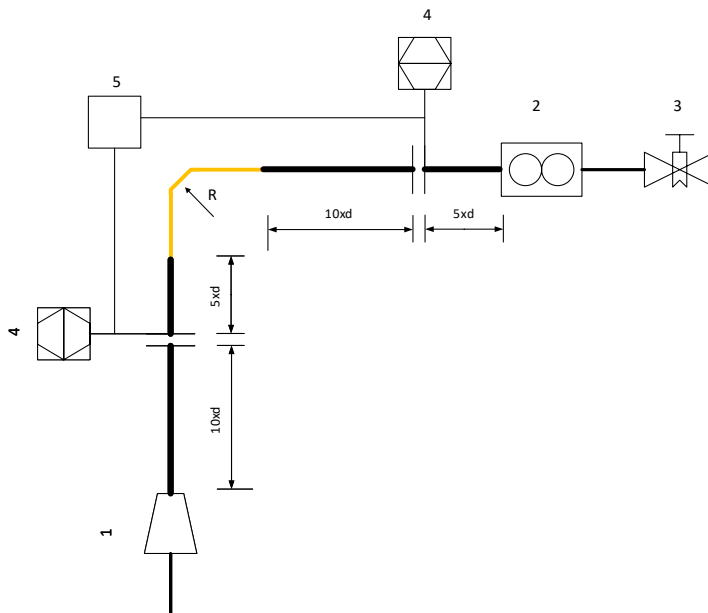

Figure 1

- 1 = pressure regulator inlet pressure
- 2 = flow meter
- 3 = control valve
- 4 = pressure meter
- 5 = pressure differential meter

nominal internal diameter (mm/inch)	R (mm)	d (mm)
20 (¾")	35	21
25 (1")	55	27
40 (1½")	90	41
50 (2")	125	52

Table 3

4.5 Strength of fittings

Fittings with a flat sealing shall be able to withstand a torque of 3,5 Nm per mm nominal diameter, without showing any deformation, damage or leakage.

If the fitting is secured by means of a spring ring, the union nut shall be able to withstand a torque of 6 Nm per mm nominal diameter without any deformation, damage or leakage.

4.5.1 Test method

The fitting of the gas meter connection tube is connected to a suitable connecting part. The fitting is then tightened with a torque equivalent to 3,5 Nm or 6 Nm per mm internal diameter of the tube. Visually inspected for deformation or damage. The leak tightness shall be verified according to section 4.3.

4.6 Resistance to internal pressure

The gas meter connection tube shall be able to withstand an internal water pressure of 16 bar for 5 minutes without showing any deformation, damage or leakage.

4.6.1 Test method

The gas meter connection tube is closed at one side and completely filled with water, it shall be ensured that all the air has been removed. A pressure of 16 bar is applied to the tube, this pressure is maintained for 5 minutes during which the tube is inspected for deformation and leakage.

4.7 Resistance to pull out

The gas meter connection tube shall be able to withstand an axial load of 140 N per mm internal diameter without deformation or leakage.

4.7.1 Test method

The gas meter connection tube is connection to a pulling device. The tube is pressurized with a pressure of 300 mbar. Using the pulling device, a tensile force is applied to the gas meter connection equal to 140 N per mm of the internal diameter of the tube. This tensile force is maintained for 5 minutes during which the tube is inspected for deformation and leakage.

4.8 Resistance to bending

After being stretched lengthwise for 15 %, it shall be possible to bend the gas meter connection tube 30 times to an angle of 180° without showing damage or leakage.

4.8.1 Test method

The length of the gas meter connection tube is stretched to 115% (length excluding the fittings). The gas meter connection tube is connected to a gas pipe according to figure 2. On both sides of the fitting A of the gas meter connection tube two mandrels D are positioned with a diameter according to table 4 below.

nominal internal diameter (mm/inch)	mandrel diameter (D) (mm)
20 (3/4")	35
25 (1")	55
40 (1½")	90
50 (2")	125

Table 4

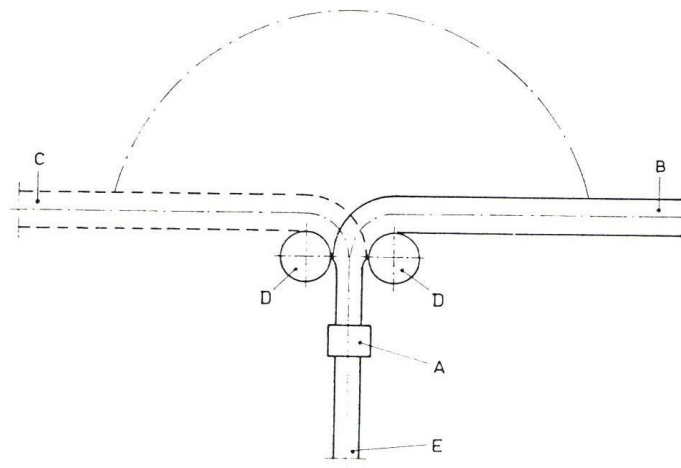

Figure 2

- A = fixed grip of the pipe
- B = position at the start of the test
- C = position after bending
- D = mandrel
- E = gas pipe

The horizontal axis of the mandrels must be at the height of the first complete corrugation. The distance between the vertical axes of the mandrels as regards to the axis of the fitting A must be such that the mandrels touch the corrugated construction of the gas meter connection tube without gripping it.

The gas meter connection tube is bent into the initial position indicated by the solid lines and next the free end is bent along the dash-dot line from position B into position C. After this the gas meter connection is again bent, this time from position C to position B.

A movement from B to C or from C to B counts as one bend; a bend is carried out at a uniform speed in ± 10 seconds. After each bend the gas meter connection must touch the mandrel over 90° . After 30 bends the gas meter connection is inspected for damaged and leak tightness according to section 4.3.

4.9 Resistance to impact

The gas meter connection tube shall be able to withstand the impact of a falling load of 100 N from a height according to table 5, at a right angle to the axis of the corrugated pipe, without showing any leakage.

nominal internal diameter (mm/inch)	Height in mm
20 (3/4")	800
25 (1")	1000
40 (1½")	1200
50 (2")	1400

Table 5

4.9.1 Test method

A gas meter connection tube is laid down on a horizontal plate. From a height according to table 5 a weight of 10 kg is drop onto the gas meter connection tube such that the corrugated tube is hit equally over a length of 70 mm.

The length of 70 mm shall be achieved by placing a rectangular wooden block lengthwise on the corrugated tube starting at the second complete corrugation from the fitting. See figure 3.

After this test the gas meter connection tube shall be tested according to section 4.3.

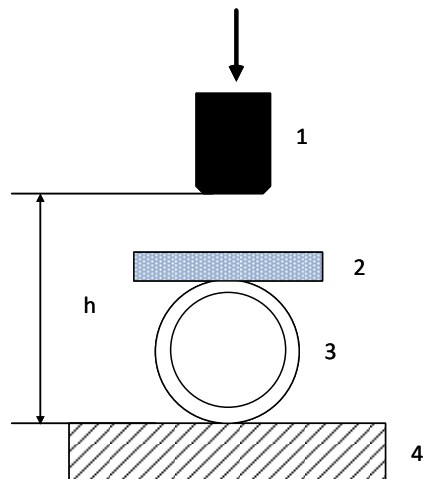

Figure 3

- 1 = weight 10 kg
- 2 = multiplex block 70 mm length, thickness 30 mm
- 3 = gas meter connection tube
- 4 = flat surface
- h = height according to table 5

4.10 Self-extinguishing test method

The plastic of the protective layer shall be heated with a colourless flame of a full burning 1.8 kW Bunsen burner until flames are visible. After the Bunsen burner has been removed, the flames shall extinguish.

5 Marking, instructions and packaging

5.1 Marking

The products shall be clearly and durable marked with:

- GASTEC QA word mark, logo or punch mark
- year and month of manufacture
- name or trademark of the supplier

The method of marking may not affect or damage the corrugated part of the connection tube.

5.2 Instructions

Installation instructions shall be provided on or in the packaging and shall contain at least the following text in the Dutch language;

- Prevent any damage occurring during installation.
- Take care that the corrugated metal tube does not become twisted.
- The minimum bend radius.

In addition, the following information shall be provided in the installation instructions:

- The pressure loss
- A drawing with example(s) of the correct way of mounting the connection tube.

5.3 Packaging

Each connection tube shall be protected against any possible damage during storage and transport.

6 Quality system requirements

The supplier shall make a risk assessment of the product and production process according to chapter 3.1.1.1 and 3.1.2.1 of the GASTEC QA general requirements. The risk assessments shall be available to Kiwa for review.

7 Summary of tests

This chapter contains a summary of tests to be carried out during:

- The initial product assessment;
- The periodic product verification;

7.1 Test matrix

Description of requirement	Clause	Test within the scope of		
		Initial product assessment	Product verification	
			Verification	Frequency
Material	3.1	X		
Construction	3.2	X		
Dimensions	3.3	X	X	Each year
Stress corrosion resistance	4.2	X	X	Each year
Leak tightness	4.3	X		
Pressure loss	4.4	X		
Strength of fittings	4.5	X		
Resistance to internal pressure	4.6	X	X	Each year
Resistance to pull out	4.7	X	X	Each year
Resistance to bending	4.8	X	X	Each year
Resistance to impact	4.9	X		
Marking	5.1	X	X	Each year
Instructions	5.2	X		
Packaging	5.3	X		

8 List of referenced documents

8.1 Standards / normative documents

All normative references in this Approval Requirement refer to the editions of the standards as mentioned in the list below.

EN 437: 2003+A1: 2009	Test gases- test pressure – appliance categories
EN 549: 1995	Rubber materials for seals and diaphragms for gas appliances and gas equipment
EN 682: 2002+A1: 2005	Elastomeric seals – materials requirements for seals in pipes and fittings carrying gas and hydrocarbon fluids
ISO 6957: 1988	Copper alloys - Ammonia tests for stress corrosion resistance
ISO 10380: 2012	Pipework – corrugated metal hoses and hose assemblies